

CAD FILE:

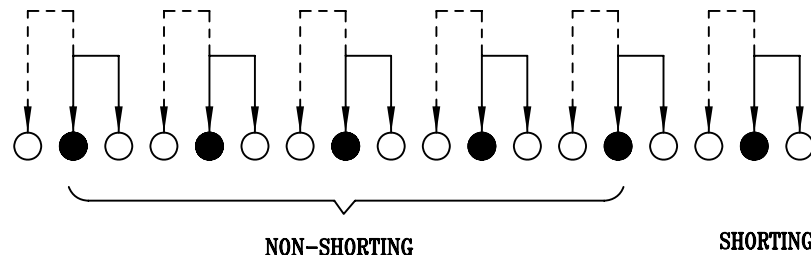

SCHMATIC

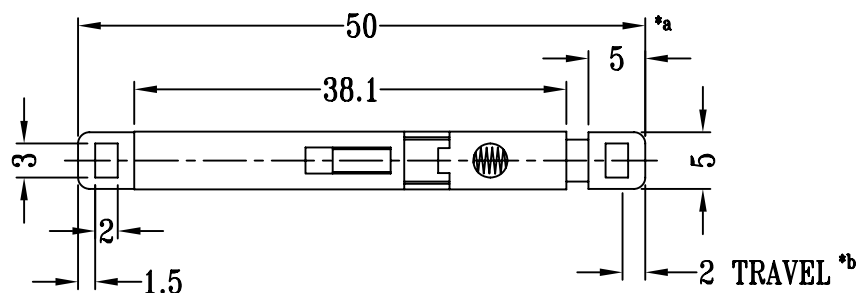
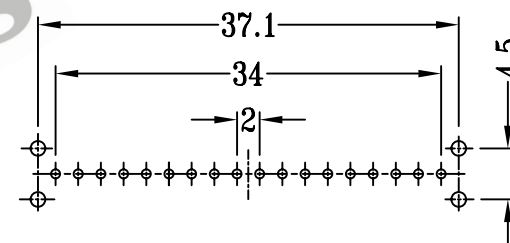
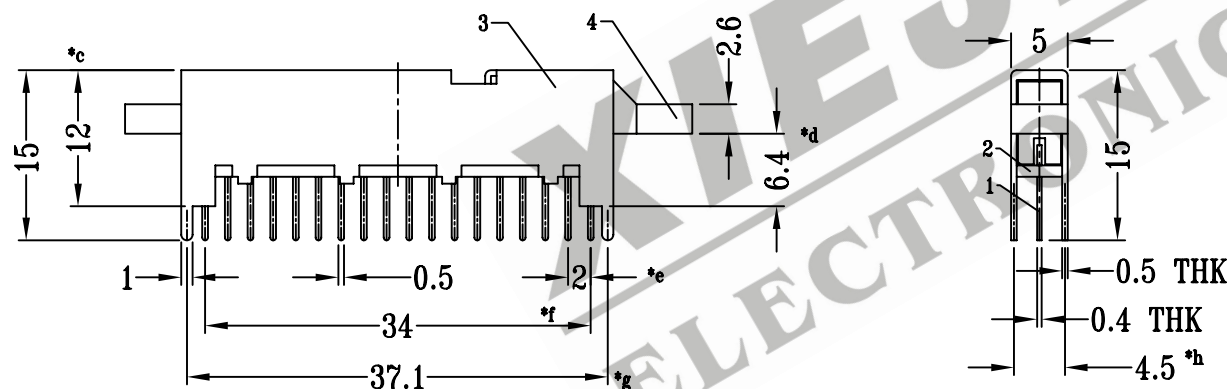

P.C.B LAYOUT

注:带"*"表示关键尺寸(8个)

NO.	PARTS	MATERIALS	Q'TY	FINISH	TOLERANCE UNLESS SPECIFIED	SHENZHEN XIEJIA ELECTRONICS CO.,LTD.																										
8						<table border="1"> <tr> <td>ISSUE</td> <td>DATE</td> <td colspan="2">DESCRIPTIONS OF REVISION</td> <td>APPD.</td> </tr> </table>				ISSUE	DATE	DESCRIPTIONS OF REVISION		APPD.																		
ISSUE	DATE	DESCRIPTIONS OF REVISION		APPD.																												
7																																
6	SPRING	STEEL WIRE	1	NATURAL	WITHIN : 1.5±0.1mm OVER : 1.5±0.2mm	<table border="1"> <tr> <td colspan="2">TITLE : PUSH SWITCH</td> <td>UNIT : mm</td> <td colspan="2">DRWG NO.: XJ-DR-PS62D09-00</td> </tr> <tr> <td colspan="2">MODEL: PS-62D09</td> <td>SCALE: 3:2</td> <td>DWN.</td> <td>ZHOUYU</td> <td>2003-4-8</td> </tr> <tr> <td colspan="2"></td> <td></td> <td>CHK'D</td> <td>FANGYING</td> <td>2003-4-8</td> </tr> <tr> <td colspan="2"></td> <td></td> <td>APPD.</td> <td>KANGXINAN</td> <td>2003-4-8</td> </tr> </table>				TITLE : PUSH SWITCH		UNIT : mm	DRWG NO.: XJ-DR-PS62D09-00		MODEL: PS-62D09		SCALE: 3:2	DWN.	ZHOUYU	2003-4-8				CHK'D	FANGYING	2003-4-8				APPD.	KANGXINAN	2003-4-8
TITLE : PUSH SWITCH		UNIT : mm	DRWG NO.: XJ-DR-PS62D09-00																													
MODEL: PS-62D09		SCALE: 3:2	DWN.	ZHOUYU	2003-4-8																											
			CHK'D	FANGYING	2003-4-8																											
			APPD.	KANGXINAN	2003-4-8																											
5	CONTACT CLIP	PBS	6	Ag PLATED																												
4	KNOB	NYLON+F.G+94V0	1	BLACK																												
3	FRAME	STEEL STRIP	1	Ni PLATED																												
2	BASE	PHENOLIC RESIN	1	NATURAL																												
1	TERMINAL	BRASS STRIP	18	Ag PLATED OVER Ni PLATED																												
					ALL MATERIALS MUST BE COMPLIANT TO ROHS																											